

CleanSpace™

wearable protective masks



USER INSTRUCTIONS

www.cleanspacetechnology.com



■ **CleanSpace EX** PAF-0060

■ **CleanSpace Ultra** PAF-0070

CleanSpace Technology Pty Ltd

Unit 5, 39 Herbert St

T: +61 2 8436 4000

ABN 24 146 453 554

St Leonards NSW 2065 Australia

sales@CleanSpaceTechnology.com

1. Contents

1.	Contents	2
2.	Foreword.....	3
3.	List of Warnings	3
4.	Special or Critical User Instructions	3
5.	Limitations of Use	4
6.	System Components	5
7.	Controls and Indicators	8
8.	Using the CleanSpace Respirator with Half Mask	9
9.	Using the CleanSpace Respirator with Full Face Masks	18
10.	Entering and Exiting the Contaminated Area	25
11.	Working in Noisy Environments	26
12.	Changing the Filter	26
13.	Battery Information	28
14.	Cleaning.....	30
15.	Recalibration.....	31
16.	Approvals.....	31
17.	Specifications	35
18.	Product Warranty.....	36

Important: Before use, the wearer must read and understand these user instructions. Keep these user instructions for reference.

Read these instructions in conjunction with the instructions for the appropriate CleanSpace filters and accessories.

WARNING

*This product is part of a system that helps protect against certain airborne contaminants. **Misuse may result in sickness or death.** For proper use, consult an Occupational Health Specialist, refer to these User Instructions, or contact CleanSpace Technology Customer Service on +612 8436 4000.*

SPECIAL CONDITIONS OF USE

- *The battery shall only be charged in non-hazardous areas*
- *Charging voltage $U_m+14.7V$ from an/via an Ex certified intrinsically safe category I (Ex ia) device*
- *CleanSpace Ex uses a unique charger designed for use with CleanSpace Ex only. Do not attempt to charge your CleanSpace EX with any other charger. Do not use the Ex charger to charge any device other than CleanSpace Ex.*

2. Foreword

Read all instructions and warnings in these User Instructions before using this device. Keep these User Instructions for reference. If you have questions regarding this system, contact CleanSpace Customer Service on +612 8436 4000 or e-mail sales@cleanspacetechnology.com.

3. List of Warnings

This product is part of a system that helps protect against certain airborne contaminants.

WARNING: Properly selected, used, and maintained respirators help to protect against certain airborne contaminants by reducing concentrations in the wearer's breathing zone. It is essential to follow all instructions and government regulations on the use of this product, including wearing the complete respirator system during all times of exposure, in order for the product to help protect the wearer. Misuse of respirators may result in overexposure to contaminants, and lead to sickness or death. For proper use, consult an Occupational Health Specialist, refer to these User Instructions, or contact CleanSpace Customer Service on +612 8436 4000.

No PAPR can fully protect you if you are not clean shaven. CleanSpace Respirators are not suitable for users with facial hair.

IF A SATISFACTORY FIT FACTOR CANNOT BE ACHIEVED WITH ANY OF THE MASKS, CLEANSACE RESPIRATORS MUST NOT BE USED.

CleanSpace Respirators are a complete respiratory protection system. In addition, some combinations of components have been approved for use in some explosive atmospheres.

Only specific combinations of components have been approved for use in explosive atmospheres. Refer to Section 16. Approvals.

The IECEx / ATEX / ETL approvals apply only when all components are IECEx / ATEX / ETL approved. If the equipment is to be used in an explosive atmosphere, ensure proper approval exists when purchasing spare parts and accessories.

Not all components and accessories shown in this manual carry IECEx / ATEX / ETL approval.

If working in intrinsically safe environments, before each of an intrinsically safe mask - check that the black conductive coating on the mask has not been significantly damaged.

WARNING: The battery shall only be charged in non-hazardous areas. Move out of the hazardous area before charging CleanSpace Respirators.

WARNING: Be sure to remove the Seal Check Cap before entering the contaminated area. The cap blocks the exhalation valve, preventing your exhaled air to be expelled from the mask. Failure to remove the cap will lead to a build-up of carbon dioxide in the mask, and may result in headache or dizziness. Never leave the cap in place for more than 2 minutes!

DO NOT REMOVE THE CLEANSACE RESPIRATOR UNTIL YOU HAVE VACATED THE CONTAMINATED AREA unless you have pressing health reasons to do so (for instance if you are experiencing dizziness and believe removing the respirator while leave the contaminated area may help).

IT IS ESSENTIAL THAT THE CORRECT FILTER TYPE IS SELECTED FOR THE CHOSEN APPLICATION.

If the Filter Warning Alarm is triggered (two (2) beeps repeated every second and red LED flashes), leave the contaminated area immediately and investigate.

Using the CleanSpace Respirator after the Filter Warning Alarm has triggered can cause the flow to fall below the manufacturer's Minimum Design Flow, which may result in overexposure to contaminants and lead to sickness or death.

Use only CleanSpace filters with the CleanSpace Respirator. Use of other filters may result in overexposure to contaminants and lead to sickness or death.

Do not charge the Power Unit with unapproved chargers, in enclosed cabinets without ventilation, near flammable liquids or gasses, or near sources of high heat.

Do not use, charge, or store the device outside the recommended temperature limits.

If the Low Battery Alarm sounds (three (3) beeps repeated every second), leave the contaminated area immediately and recharge the battery.

Operating the respirator after the Low Battery Alarm has sounded can cause the flow to fall below the manufacturer's Minimum Design Flow, and may result in overexposure to contaminants and lead to sickness or death.

IN THE EXTREMELY RARE CIRCUMSTANCE THAT THE BATTERY IS DAMAGED AND ELECTROLYTE COMES IN CONTACT WITH EYES, FLUSH WITH WATER IMMEDIATELY AND SEEK URGENT MEDICAL ATTENTION.

WARNING: NEVER DRY THE MASK OR EXHALATION VALVE WITH A CLOTH THAT MAY LEAVE BEHIND LINT.

Lint contamination of the exhalation valve may cause it to leak, resulting in overexposure to contaminants and lead to sickness or death.

WARNING: The Power Unit contains a battery, sensitive electronics and a motor. DO NOT immerse the Power Unit in water or use anything wetter than a damp cloth to clean it.

WARNING: NEVER CLEAN THE FILTER WITH COMPRESSED AIR OR A BRUSH. HEPA filters are easily damaged by the use of compressed air or by brushing.

Misuse of the CleanSpace Respirators by cleaning the filter may result in overexposure to contaminants and lead to sickness or death.

You must recalibrate the internal pressure sensor any time that the CleanSpace Respirator is exposed to changes in temperature of more than 20°C.

4. Special or Critical User Instructions

CleanSpace Respirators include a system that detects and corrects for changes in atmospheric pressure. This system requires recalibration whenever it experiences a change in temperature of more than 20°C. Refer to Section 15 for instructions on how to recalibrate the CleanSpace Respirator.

5. Limitations of Use

Use the CleanSpace Respirator strictly in accordance with these User Instructions. DO NOT modify or alter this product.

- **DO NOT USE** for respiratory protection against unknown atmospheric contaminants, when concentrations of contaminants are unknown, or **immediately dangerous to life or health** (IDLH).
- **Do not use if the oxygen concentration is below 19.5%.**
- **Do not remove the CleanSpace Respirator until you have left the contaminated area**, unless you have pressing health reasons to do so, (for instance you are experiencing dizziness and believe removing the respirator while leaving the contaminated area may help).
- Only suitable for use by clean-shaven personnel. Facial hair under the seal reduces protection and is not permitted.
- Unless used with a CleanSpace Full Face Mask, the CleanSpace respirator DOES NOT PROTECT YOUR EYES. In conditions that may damage or irritate eyes, use protective eyewear.
- Only use CleanSpace approved filters and accessories.
- Do not use the CleanSpace Respirator unless it is powered and running normally.
- Do not use the CleanSpace Respirator while it is connected to the charger.
- Do not use in airborne contaminant concentrations above those specified by your national regulations.
- Only for use by trained personnel.
- Filters need to be changed regularly. The frequency of filter changes depends on CleanSpace Respirator use and on the concentration of contaminants in the environment.
- Do not use for escape purposes.
- National regulations may impose specific limitations on the use of filters depending on the filter class and the facemask used.

LEAVE THE CONTAMINATED AREA IMMEDIATELY IF:

- CleanSpace Respirator warning lights or sounds activate for the Low Battery Alarm or the Blocked Filter Alarm
- Any part of the respirator is damaged
- Air flow into the mask decreases or stops
- Breathing becomes difficult or increased resistance occurs
- You feel dizzy or your airway is irritated
- You can taste or smell contaminants

Your CleanSpace Respirator is suitable for use in the following atmospheric conditions:

- Temperature: -10°C to 45°C (Note: Explosive atmospheres approvals apply up to maximum ambient temperature of 40°C).
- Relative humidity: 0 to 90% non-condensing.

The CleanSpace Respirator will stop functioning if its internal temperature rises above 60°C (ambient 50°C) or falls below -10°C.

If the CleanSpace Respirator has become contaminated with a substance requiring special decontamination procedures, it should be sealed in a suitable container until it can be decontaminated.

Do not disassemble the CleanSpace Respirator case. There are no user serviceable parts inside.

Failure to follow all instructions on the use of this product may render the warranty void.

Failure to use the CleanSpace Respirator properly during times of exposure may lead to adverse effects on the wearer's health.

WARNING

This product is part of a system that helps protect against certain airborne contaminants. Misuse may result in sickness or death. For proper use, consult an Occupational Health Specialist, refer to these User Instructions, or contact CleanSpace Technology Customer Service on +612 8436 4000.

6. System Components

CleanSpace Respirator is a complete respiratory protection system. Only specific combinations of components have been approved for use in some explosive atmospheres. Not all of the components shown below have been approved for use in explosive atmospheres. Refer to Section 16. Approvals below for details.

1A PAF-0064	Half Mask – Small, EX	2A PAF-0035	Filter P3 TM3 P SL R Standard	3A PAF-0065, 67 & 72	Filter Cover, Ultra & Ex
1B PAF-0062	Half Mask – Medium, EX	2B PAF-0037	Filter P3 TM3 P SL R High Capacity	3B PAF-0038	Filter Adaptor (large case filters)
1C PAF-0063	Half Mask – Large, EX	2C PAF-1037	Filter HEPA/HE High Capacity	3C PAF-0078	Conductive Filter Adaptor, EX
1D PAF-0033	Half Mask – Small	2D PAF-1003	Filter HEPA/HE High Capacity	4A PAF-0073	Head Harness- Half mask
1E PAF-1010	Half Mask – Medium	2E PAF-0091	Combined filter ABE1P3 (AU)	4B PAF-1016	Head Harness – Full Face
1F PAF-0027	Half Mask – Large	2F PAF-0076	Combined filter ABEK1P3 (AU)	5 PAF-0034, 60, 70	Power Unit 2, EX & Ultra
1G PAF-1014	Full Face Mask (M/L)	2G PAF-0050	Combined filter TM3 A1 P SL R (EU)	6A PAF-1028	Neck support (Small)
1H PAF-1106	Full Face Mask (S)	2H PAF-0051	Combined filter TM3 ABE1 P SL R (EU)	6B PAF-1012	Neck Support (Medium)
		2I PAF-0052	Combined filter TM3 ABEK1 P SL R	6C PAF-1013	Neck Support (Large)
		2J PAF-0077	Combined filter TM3 A2 P SL R (EU)	7A PAF-1005	Flow Test Cap
				7B 1101	Battery Chargers 2,Ultra & EX
				7C PAF-1009	Seal Check Cap

*NOTE: Not all filters are available in all markets.

Figure 1 - System Components

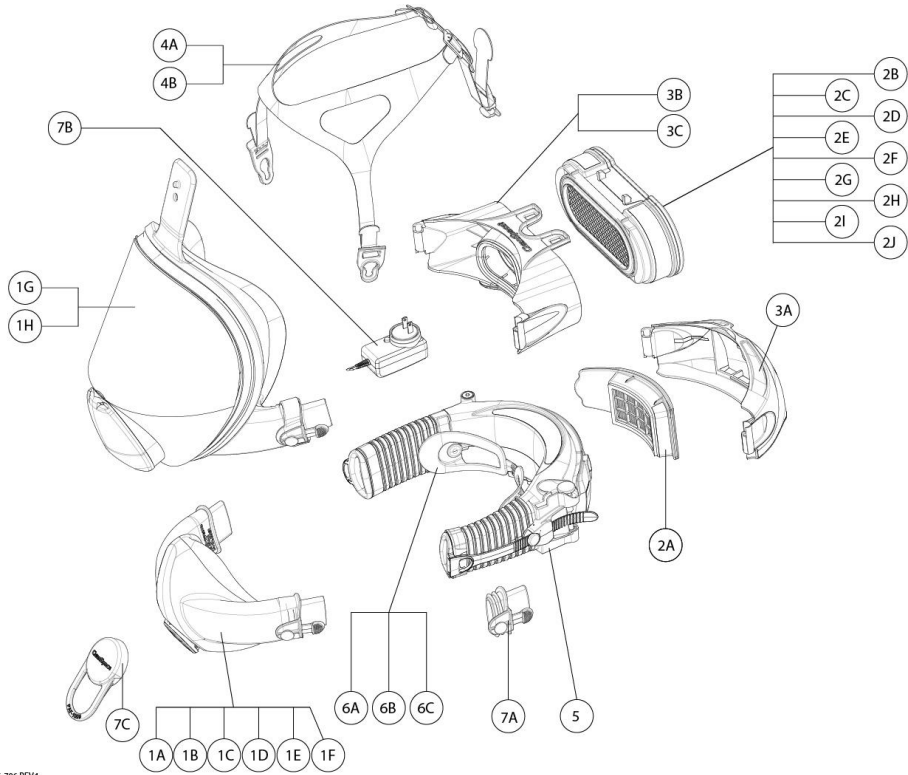

5006-706 REV4

COMPONENTS OF THE CLEANSPACE RESPIRATOR

Throughout these User Instructions, reference is made to various components of the CleanSpace Respirator. Familiarise yourself with these components before reading the rest of the User Instructions. See Figure 1 – System Components.

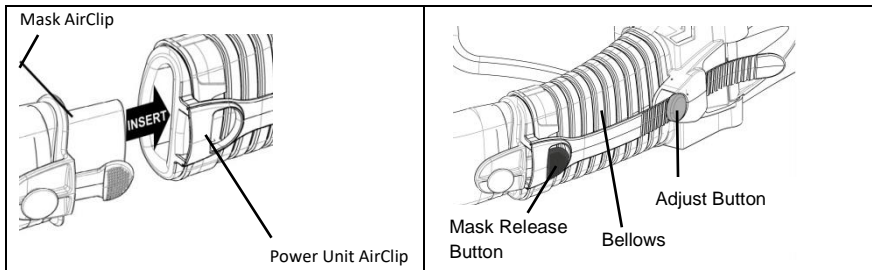

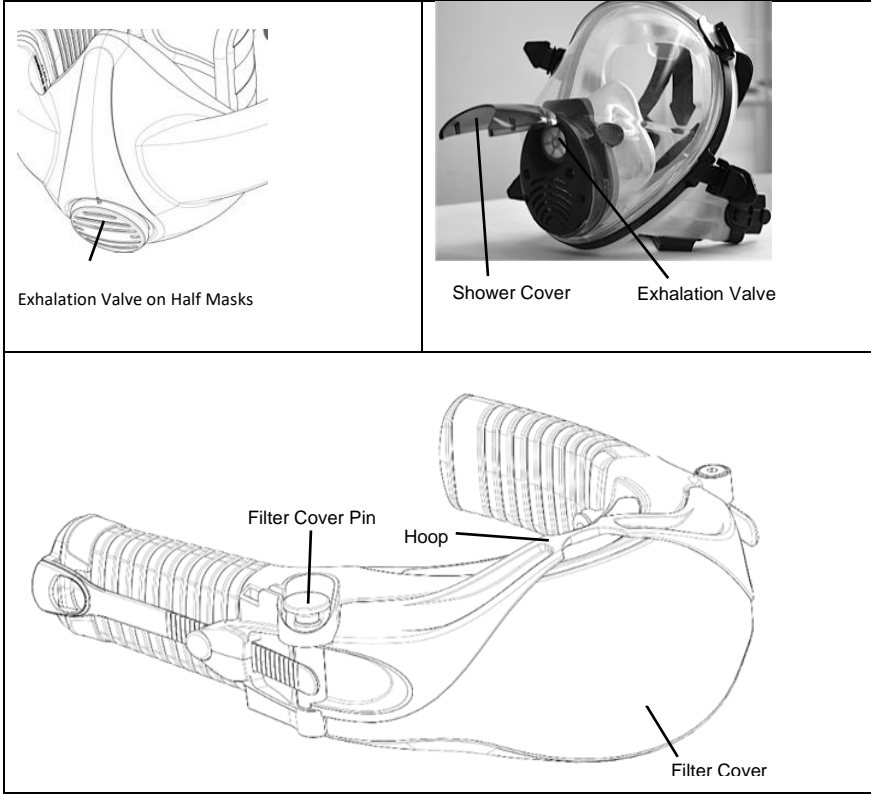

7. Controls and Indicators



All controls and indicators are located on the **keypad**.

POWER BUTTON

This button is used to switch between the three (3) operating Modes: “Off”, “Standby”, and “On”.

i) **Off Mode** is when the green battery indicator lights are off, the motor is not running, and there is no airflow to the mask. The CleanSpace Respirator automatically switches to Off Mode after three (3) minutes in standby mode with no breathing sensed.

ii) **Standby Mode** is when the green battery indicator light(s) are on, the motor is not running, and there is no airflow to the mask. If the CleanSpace Respirator is in Off Mode, it will switch to Standby Mode when the Power Button is pressed. The CleanSpace Respirator will automatically switch to Standby Mode within ten (10) seconds of the user doffing the respirator.

iii) **On Mode** is when the CleanSpace Respirator is being worn, the motor is running, and there is airflow to the mask. If the CleanSpace Respirator is in Standby Mode, it will switch to On Mode when breathing is detected, or the Power Button is pressed.



To conserve battery life when not being worn, the CleanSpace Respirator is designed to automatically switch from On Mode to Standby Mode, and then to Off Mode.

Note: The CleanSpace Respirator switches to On Mode when the respirator is in Standby Mode and breathing is detected. The CleanSpace Respirator can only switch into On Mode from Standby Mode.

FLOW TEST BUTTON

The Flow Test Button measures the rate of flow produced by the CleanSpace Respirator to ensure it is able to deliver the minimum design flow. When the CleanSpace Respirator is in Standby Mode (not On Mode), pressing the Flow Test Button initiates Flow Test. This lasts about 5 seconds.

Refer to Section 9 for instructions on running the flow test.



BATTERY INDICATOR LIGHTS

The CleanSpace Respirator is equipped with a battery charge indicator comprised of three (3) battery indicator lights. The battery is fully charged when the charger is connected to the Power Unit and all three (3) lights are solid green. A fully charged Power Unit has a minimum of four (4) hours operating time.



The CleanSpace Respirator should be fully charged before use.

The CleanSpace Respirator will operate with one (1), two (2), or three (3) green battery indicator lights illuminated. When all battery lights extinguish, the Power Unit had less than on (1) hour of operation remaining. It is recommended that the CleanSpace Respirator be charged before use.

For approximate operating times, refer to Section 13. Battery Information.

LOW BATTERY ALARM

The Low Battery Alarm is triggered when the battery charge decreases beyond level at which it may not be able to supply the manufacturer’s Minimum Design Flow. The Low Battery Alarm consists of three (3) beeps, repeated once per second and all battery indicator lights extinguish.

If the Low Battery Alarm is triggered, you must leave the contaminated area immediately and recharge the battery.

The Low Battery Alarm cannot be muted.

Battery life is strongly affected by work rate, atmospheric pressure, and other factors. The approximate operating times stated in Section 13. Battery Information are typical for moderate work rates at sea level. Actual operating times may vary widely.

FILTER WARNING ALARM

The Filter Warning Alarm is triggered if the filter is blocked. The Filter Warning Alarm consists of two (2) beeps, repeated once per second, and the red LED flashes.

The Filter Warning Alarm can be muted for 15 minutes by pressing the Power Button once.

If the Filter Warning Alarm is triggered, you must move out of the contaminated area IMMEDIATELY and change the filter.



8. Using the CleanSpace Respirator with Half Mask

MASK FITTING FOR HALF MASK

Intrinsically Safe	NOT – Intrinsically Safe
PAF-0064 EX Half Mask Small	PAF-0033 Half Mask Small
PAF-0062 EX Half Mask Medium	PAF-1010 Half Mask Medium
PAF-0063 EX Half Mask Large	PAF-0027 Half Mask Large

Determine the correct mask size and achieve a good fit prior to using the CleanSpace Respirator.

Mask fitting must be carried out by a specialist / designated mask fitter. The fit must be confirmed by a **quantitative fit test**.

To carry out a quantitative fit test the specialist / designated mask fitter will require the **PAF-0025 PortaCount Adaptor** and the accompanying **S005-7174 Quantitative Fit Test Instructions**. The PortaCount Adaptor is an accessory that fits between the mask and exhalation valve, allowing the air in the mask to be sampled.

No PAPR can fully protect you if you are not clean shaven. CleanSpace Respirator is not suitable for users with facial hair.

MASK SELECTION GUIDELINES

No set of guidelines can ensure a good fit. Fit must be confirmed with a **quantitative fit test**. The table below is a guideline for the specialist / designated mask fitter.

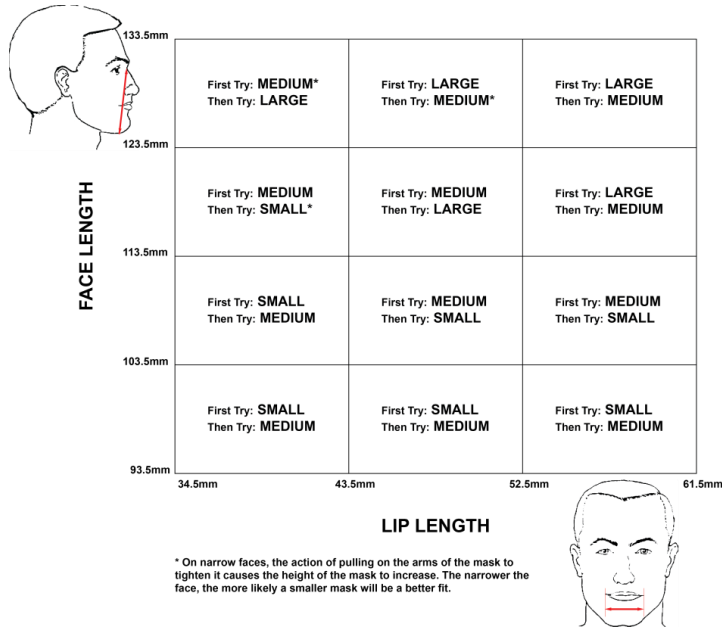

Once an acceptable mask fit has been achieved, and then confirmed with a quantitative fit test, the table below may be used as a record.

Name	
Mask Size	
Neck Support	Small / Medium / Large (Circle one)
Date of Quantitative Fit Test	
Fit Factor achieved	

IF A SATISFACTORY FIT FACTOR CANNOT BE ACHIEVED WITH ANY OF THE MASKS, CLEANSPACE RESPIRATORS MUST NOT BE USED.



WARNING

If a satisfactory quantitative fit factor or a qualitative test pass cannot be achieved with either mask, the CleanSpace Respirator must not be used.

Satisfactory quantitative fit factor results are as follows.

Test Type	Half Mask	Full Face Mask
Power On	1000	1000
Power Off	100	500

USING THE CLEANSPACE RESPIRATOR WITH HALF MASK

Complete the following steps each time you use CleanSpace Respirator with Half Mask.

Prior to entering a potentially contaminated area, the following inspection must be performed.

STEP 1 – INSPECT THE CLEANSPACE RESPIRATOR

- Visually inspect all the CleanSpace Respirator components, (Power Unit, mask, harness, filter adaptor, and filter). If any components are missing or damaged, replace them only with approved CleanSpace Respirator parts before proceeding. Check the top and bottom case of the Power Unit, and the Filter Adaptor (if fitted) for cracks or other damage. Do not use the CleanSpace Respirator if there is any damage.
- Remove the filter and inspect it carefully. The seal must be clean, and free from damage of any kind. If necessary, the seal and housing can be cleaned with a cloth dampened with water. (The filter media must not be exposed to water). Inspect the surfaces behind the filter carefully for any sign that dust has leaked past a damaged seal. If dust is found, replace the filter. The filter media must not be cracked or show any sign of damage. Inspect the filter carefully for any sign that it has sustained an impact or been scratched. If any sign of impact or scratching is found, discard the filter. If the filter inspection is satisfactory fit the filter and check that it is secure (refer to Section 12 Changing the Filter).

WARNING: NEVER CLEAN THE FILTER WITH COMPRESSED AIR OR A BRUSH. HEPA FILTERS ARE EASILY DAMAGED BY THE USE OF COMPRESSED AIR OR BY BRUSHING.

Misuse of the CleanSpace Respirator by cleaning the filter may result in overexposure to contaminants and lead to sickness or death.

- Inspect that the battery has enough charge to complete the work period by pressing the Power Button. The Battery Indicator Light(s) will illuminate to indicate the approximate charge. Refer to Section 7 Controls and Indicators. A full charge is recommended.
- Inspect both bellows for cuts or holes. Check that the bellows have not become distorted as this may obstruct the air supply.
- Inspect the mask to ensure that there are no cracks, tears, or dirt. The mask should not be warped.
- Inspect the exhalation valve for damage or dirt. If dirt is present, remove the exhalation valve cover. Remove any contaminants that could affect the seal of the valve. Check that the valve seat is clean. Reinstall the exhalation valve cover. If the valve is damaged, replace the exhalation valve.
- Inspect the harness for damage.

STEP 2 – RECALIBRATE THE POWER UNIT

The CleanSpace Respirator contains a system that detects and corrects for changes in atmospheric pressure. **This system requires recalibration whenever a change in temperature of more than 20°C is experienced.**

Recalibration procedure:

1. With no mask attached, place the Power Unit on a flat surface with the keypad facing up.
2. With the Power Unit in standby mode (one or more Battery Indicator Light(s) illuminated), press and hold **both** the Power Button and the FLOW TEST Button.
3. When both the blue and red indicator lights illuminate, release both buttons.
4. Do not move the Power until the red and blue indicator lights extinguish; approximately(10 – 15 seconds).
5. Recalibration is complete.

The CleanSpace Respirator automatically recalibrates the system any time it is left **undisturbed in Standby Mode** for more than 20 seconds.

STEP 3 – TEST FLOW RATE ON THE POWER UNIT

The Flow Test verifies that the machine is able to deliver the Manufacturer's Minimum Design Flow of 120 litres/minute.

1. Fit the yellow Flow Test Cap to the **LEFT** bellow. Note: the Power Unit depicted below has the Filter Adaptor fitted. The Flow Test procedure is the same regardless of filter configuration.

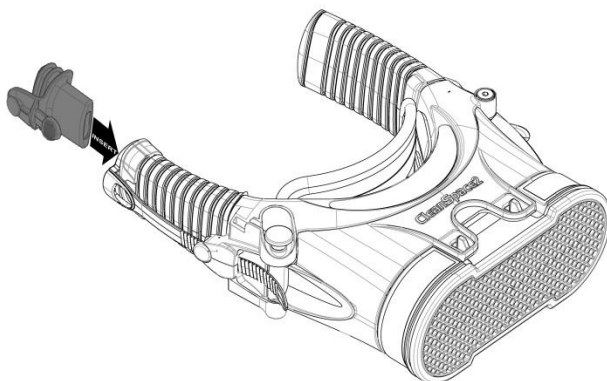

FAILURE to fit the Flow Test Cap to the LEFT bellow will FAIL the Flow Test, even if the filter is clean and the battery is fully charged.

2. Ensure the Flow Test Cap and the filter inlet are unobstructed. Place the CleanSpace Respirator on a flat surface with the keypad facing up.
3. Place the Power Unit in Standby Mode. Press and release the Flow Test button.
4. The CleanSpace Respirator runs the Flow Test automatically. The Power Unit will operate and air will be discharged from the Flow Test Cap.
5. After completion of the Flow Rate Test, the Battery Indicator Lights illuminate to display the result. Refer to the table below.

LIGHTS	Meaning
3 Lights:	PASS - Excellent (Flow >180 l/min)
2 Lights:	PASS - Good
1 Light:	PASS - Acceptable
ALL LIGHTS FLASH	<p>FAIL - (Flow <120 l/min)</p> <p>Do not use the CleanSpace Respirator until a new filter has been fitted and / or battery charged and the Flow Test has been repeated with a PASS result.</p> <p><i>Reset the CleanSpace respirator by pressing the Power Button. Fully charge the battery and / or replace the filter. Repeat the flow test. If the CleanSpace respirator continues to FAIL the Flow Test, with a new filter fitted and battery, do not use until it has been evaluated. Contact CleanSpace Technology.</i></p>

6. Remove the yellow Flow Test Cap and store for later use.

STEP 4 - DON THE CLEANSAPCE RESPIRATOR WITH HALF MASK

NOTE: Please this step in its entirety prior to donning the CleanSpace Respirator.

Collect the Power Unit, mask, neck support and harness. **Ensure the mask and neck support are the correct size.**

Fit the neck support to the Power Unit.

CleanSpace Respirators

USER INSTRUCTIONS

The CleanSpace Respirator comes supplied with two neck supports:

- PAF-1028 NECK SUPPORT SMALL
- PAF-1012 NECK SUPPORT MEDIUM
- PAF-1013 NECK SUPPORT LARGE

Select the appropriate size neck support.

The neck support has keyhole openings at each end which snap over buttons on the Power Unit. Place the neck support in position against the buttons and then press firmly towards the Power Unit until the buttons engage in the keyhole openings.



Fit a mask to the Power Unit

- The left hand mask arm is open, whilst the right one is closed. The figure on the right highlights the left hand (open) mask arm.
- Connect the left hand mask arm to the left hand Power Unit below. The left hand Power Unit below is on the same side as the "POWER" button.
-



Ensure the AirClip is securely fastened as shown in Figure B below.

Figure A. Connect the left hand mask arm with the bellow.



Figure B. Mask fastened to Power Unit. Note: connection is on the left hand side



IMPORTANT: Ensure the mask is the right way up. The pointed nose section of the mask must face up in the same direction as the keypad. See Figure on the right. Leave the other mask arm and bellow unattached until you don the CleanSpace respirator.

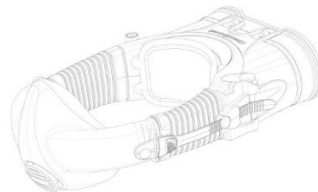

Fit the harness to the mask

Orient the harness ensuring there is a clip with a keyhole next to each arm of the mask and the rear harness strap is toward the Power Unit.



Attach the harness to the mask on both sides.



Familiarise yourself with the Adjust Buttons and the Mask Release Buttons.

Mask Release Button and Adjust Button

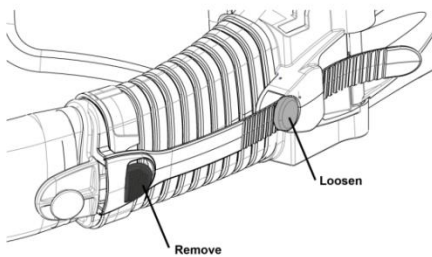



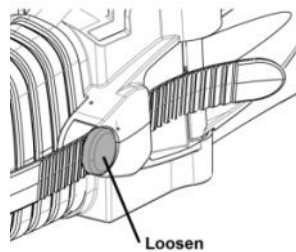

Extend both bellows to their longest setting.

Press the Adjust Button on the Power Unit and pull on the bellows to extend.



CleanSpace Respirators

USER INSTRUCTIONS

<p>Switch the Power Unit to Standby Mode. Briefly press the Power Button once. The Battery Indicator Light(s) should illuminate.</p>	
<p>Place the Power Unit behind your neck with the mask attached on the left-hand side.</p> <p>Ensure the head harness is above the mask and not tangled.</p>	
<p>Connect the right-hand Mask AirClip to the right-hand Power Unit AirClip.</p>	
<p>Locate the hook on the end of the harness rear strap. Pull the rear strap back over your head.</p>	
<p>Connect the hook to the loop located on the filter cover of the Power Unit.</p> <p>The rear strap supports the weight of the Power Unit.</p>	

Adjust Power Unit Position.

Adjust the rear strap to set the height of the Power Unit.

For most users, wearing the Power Unit level is comfortable.

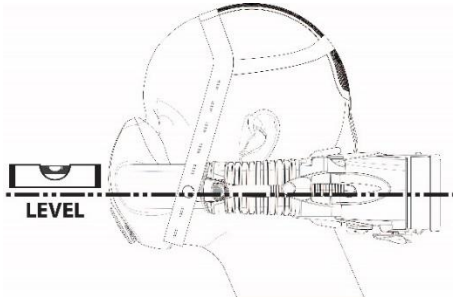
**Adjust the fit of the mask.** Ensure no leaks mask and face.

To loosen the mask, press the adjust button and extend the bellows. on the below.

To tighten the mask, place one hand against the back of the Power Unit, and the other on the mask. Push the Power Unit and the mask towards each other. You will hear a series of clicks as the bellows tighten.

Ensure the bellows are adjusted symmetrically.

**Mask Fit Requirements**

No Gaps: There should be no visible gaps between mask and face.

No Creases: If the mask is overtightened, or is too large for the face, creases may appear near the mouth, or in the centre of the bottom of the cushion. Loosen the mask, or try a smaller mask.

No gaps while looking down: Ensure no gaps exist between the bridge of the nose and the mask. Also check that the mask has not come loose around the chin. If gaps appear, try to fit the chin further into the mask, accurately positioning in the chin well. If that does not work, try a smaller mask.

No air blowing into the eyes: Ensure there is no air blowing into the eyes. If there is, try tightening the mask, or loosening the harness slightly. If this does not work, try a different size mask.

Not uncomfortably tight: A good fit should be achieved without the mask being uncomfortably tight. **Beyond a certain point, tightening makes the fit worse, not better.** If the bellows are visibly curving outward, they should be loosened.

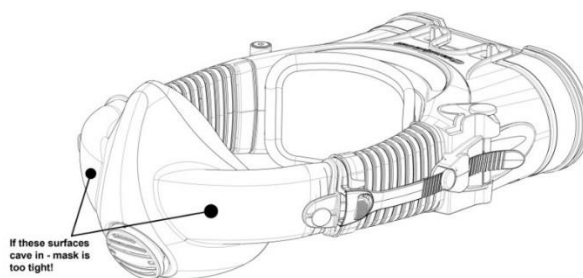

STEP 5 – CHECK MASK SEAL

A fit check must be conducted every time you wear the CleanSpace Respirator. Locate the red Seal Check Cap (PAF-1009). Fit the Seal Check Cap over mask exhalation cap. The Seal Check Cap should snap into place. See figure below.

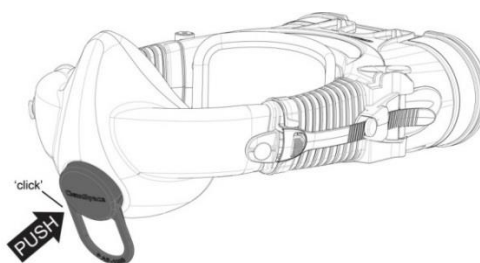

- Ensure the Seal Check Cap is security fitted. No air should be escaping from the exhalation valve.
- Breathe normally.
- Check for leaks by feeling around the edges of the mask. Exhale firmly to raise the air pressure in the mask. If still unsure whether a leak is present, wetting fingers may make it easier to detect.
- If necessary, tighten the mask. To tighten the mask, place one hand against the back of the Power Unit, and the other on the mask. Push the Power Unit and the mask towards each other. You will hear a series of clicks as the bellows tighten.
- Ensure the bellows are adjusted symmetrically.

Do not overtighten the bellows! If the front of the mask starts to cave in, the fit is too tight, leaks may appear. Press the Adjust Buttons to loosen.

After adjusting, check for leaks again

Tilt head up, down, left, and right, checking for leaks in each position. Adjust if necessary.

Once no leaks are detected, the mask seal check is complete.

IF A SATISFACTORY FIT CANNOT BE ACHIEVED, DO NOT ENTER THE CONTAMINATED ZONE

Remove the Seal Check Cap by gently **twisting** the handle so that one side of the cap comes loose from the exhalation valve. Be careful not to dislodge the exhalation valve cover. See figure on the following page.

NEVER LEAVE THE SEAL CHECK CAP IN PLACE FOR MORE THAN TWO (2) MINUTES!

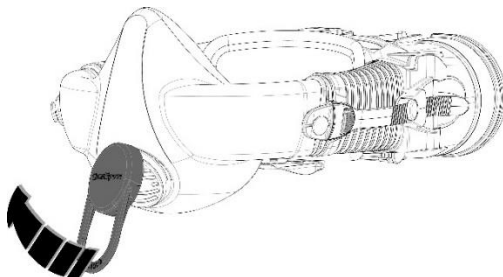

The Seal Check Cap must be removed before entering the contaminated area. The cap blocks the exhalation valve, making it more difficult for your exhaled air to be expelled from the mask. Failure to remove the cap will lead to a buildup of carbon dioxide in the mask, which could result in headache or dizziness.

Never leave the Cap in place for more than 2 minutes!

9. Using the CleanSpace Respirator with Full Face Mask

MASK FITTING –FULL FACE MASK

NOT – Intrinsicly Safe

PAF-1106 Full Face Mask Small

PAF-1014 Full Face Mask Medium

Determine the correct mask size and achieve a good fit prior to using the CleanSpace Respirator.

Mask fitting must be carried out by a specialist / designated mask fitter. The fit must be confirmed by a **quantitative fit test**.

To carry out a quantitative fit test the specialist / designated mask fitter will require the **S005-7174 Quantitative Fit Test Instructions**.

No PAPR can fully protect you if you are not clean shaven. CleanSpace Respirator is not suitable for users with facial hair.

MASK SELECTION GUIDELINES

No set of guidelines can ensure a good fit. Fit must be confirmed with a quantitative fit test.

The test is performed using a machine that compares the concentration of particles in the mask with that in the surrounding atmosphere. One example is the PortaCount Respiratory Fit Tester, made by TSI Incorporated. CleanSpace Full Face Masks come with a built-in sampling port and a sampling ball accessory which make it quick and easy to carry out a fit test.

To set up for the test, do the following. Firstly, we recommend you remove the inner mask as that makes access easier.

CleanSpace Respirators

USER INSTRUCTIONS

With the mask off your face, pull the orange plug from the Sensing Ball socket.



Locate the Sensing Ball which was supplied with your mask.



Fit the Sensing Ball. Push it all the way in. Note that there are small fins on the stem of the ball to ensure the correct orientation.



Raise the rain cover.



Remove the sealing plug from the fit test port.



Fit the mask sensing tube to the fit test port (on a TSI PortaCount it is the clear tube).



Re-fit the inner mask. The inner mask is an essential part of the Full Face Mask and is required to complete the fit test. Don the mask and begin the test, following the protocol provided with the fit testing machine. A CleanSpace Respirator with a clean filter, a full battery, and the Power Unit on, should achieve a fit factor above 1000. If your result is below 1000, adjust the mask and try again.

**WARNING**

If a satisfactory quantitative fit factor or a qualitative test pass cannot be achieved with either mask, the CleanSpace Respirator must not be used.

Satisfactory quantitative fit factor results are as follows.

Test Type	Half Mask	Full Face Mask
Power On	1000	1000
Power Off	100	500

On completion of the fit test, the Full Face Mask must be prepared for use as follows.

Remove the Sensing Ball from the Sensing Ball socket. Refit the orange plug to the Sensing Ball Socket, pushing it all the way in.

Remove the sensing tube from the fit test port. Refit the plug to the fit test port.

Lower the rain cover.

**WARNING**

A negative pressure seal check must be performed in order to ensure that the test port plug is fitted correctly after use of the on-board fit test ports. Refer to section 9, Step 4.

**WARNING**

Using the Full Face Mask with the rain cover raised can cause the exhalation valve to vibrate, which may cause a buzzing noise. For correct operation, the rain cover should be lowered.

No PAPR can fully protect you if you are not clean shaven. CleanSpace Respirator is not suitable for users with facial hair.

Once you have achieved an acceptable mask fit and confirmed it with a quantitative fit test, record your information in the table below.

Name	
Mask Type	
Neck Support	N/A
Date of Quantitative Fit Test	
Fit Factor on Test	

IF A SATISFACTORY FIT FACTOR CANNOT BE ACHIEVED WITH ANY OF THE MASKS, THE CLEANSPACE RESPIRATOR MUST NOT BE USED.

USING THE CLEANSPACE RESPIRATOR WITH FULL FACE MASK

Complete the following steps each time you use CleanSpace Respirator with FULL FACE MASK.

Prior to entering a potentially contaminated area, the following inspection must be performed.

STEP 1 – INSPECT THE CLEANSPACE RESPIRATOR

- Visually inspect all the CleanSpace Respirator components, (Power Unit, mask, harness, filter adaptor, and filter). If any components are missing or damaged, replace them only with approved CleanSpace Respirator parts before proceeding. Check the top and bottom case of the Power Unit, and the Filter Adaptor (if fitted) for cracks or other damage. Do not use the CleanSpace Respirator if there is any damage.
- Remove the filter and inspect it carefully. The seal must be clean, and free from damage of any kind. If necessary, the seal and housing can be cleaned with a cloth dampened with water. (The filter media must not be exposed to water). Inspect the surfaces behind the filter carefully for any sign that dust has leaked past a damaged seal. If dust is found, replace the

CleanSpace Respirators

USER INSTRUCTIONS

filter. The filter media must not be cracked or show any sign of damage. Inspect the filter carefully for any sign that it has sustained an impact or been scratched. If any sign of impact or scratching is found, discard the filter. If the filter inspection is satisfactory fit the filter and check that it is secure (refer to Section 12 Changing the Filter).

WARNING: NEVER CLEAN THE FILTER WITH COMPRESSED AIR OR A BRUSH. HEPA FILTERS ARE EASILY DAMAGED BY THE USE OF COMPRESSED AIR OR BY BRUSHING.

Misuse of the CleanSpace Respirator by cleaning the filter may result in overexposure to contaminants and lead to sickness or death.

- Inspect that the battery has enough charge to complete the work period by pressing the Power Button. The Battery Indicator Light(s) will illuminate to indicate the approximate charge. Refer to Section 7 Controls and Indicators. A full charge is recommended.
- Inspect both bellows for cuts or holes. Check that the bellows have not become distorted as this may obstruct the air supply.
- Inspect the mask to ensure that there are no cracks, tears, or dirt. The mask should not be warped.
- Raise the rain cover and inspect the exhalation valve for damage or dirt . If dirt is present, remove any contaminants that could affect the seal of the valve. Check that the valve seat is clean. If the valve is damaged, replace the exhalation valve. Lower the rain cover.
- Inspect the harness for damage.

STEP 2 – RECALIBRATE THE POWER UNIT

The CleanSpace Respirator contains a system that detects and corrects for changes in atmospheric pressure. **This system requires recalibration whenever a change in temperature of more than 20°C is experienced.**

Recalibration procedure:

1. With no mask attached, place the Power Unit on a flat surface with the keypad facing up.
2. With the Power Unit in standby mode (one or more Battery Indicator Light(s) illuminated), press and hold **both** the Power Button and the FLOW TEST Button.
3. When both the blue and red indicator lights illuminate, release both buttons.
4. Do not move the Power until the red and blue indicator lights extinguish; approximately(10 – 15 seconds).
5. Recalibration is complete.

The CleanSpace Respirator automatically recalibrates the system any time it is left **undisturbed in Standby Mode** for more than 20 seconds.

STEP 3 – TEST FLOW RATE ON THE POWER UNIT

The Flow Test verifies that the machine is able to deliver the Manufacturer's Minimum Design Flow of 120 litres/minute.

1. Fit the yellow Flow Test Cap to the LEFT bellow. Note: the Power Unit depicted below has the Filter Adaptor fitted. The Flow Test procedure is the same regardless of filter configuration.

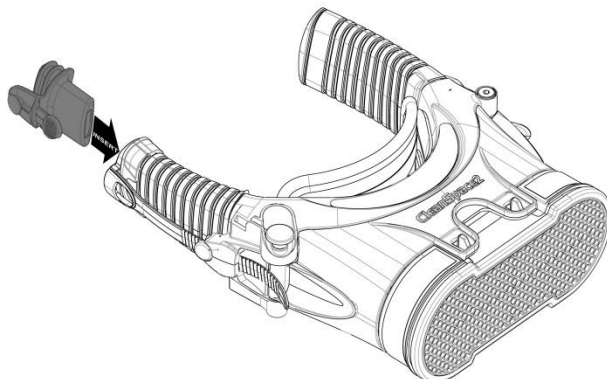

FAILURE to fit the Flow Test Cap to the LEFT bellow will FAIL the Flow Test, even if the filter is clean and the battery is fully charged.

2. Ensure the Flow Test Cap and the filter inlet are unobstructed. Place the CleanSpace Respirator on a flat surface with the keypad facing up.

3. Place the Power Unit in Standby Mode. Press and release the Flow Test button.
4. The CleanSpace Respirator runs the Flow Test automatically. The Power Unit will operate and air will be discharged from the Flow Test Cap.
5. After completion of the Flow Rate Test, the Battery Indicator Lights illuminate to display the result. Refer to the table below.

LIGHTS	Meaning
3 Lights:	PASS - Excellent (Flow >180 l/min)
2 Lights:	PASS - Good
1 Light:	PASS - Acceptable
ALL LIGHTS FLASH	<p>FAIL - (Flow <120 l/min)</p> <p>Do not use the CleanSpace Respirator until a new filter has been fitted and / or battery charged and the Flow Test has been repeated with a PASS result.</p> <p><i>Reset the CleanSpace respirator by pressing the Power Button. Fully charge the battery and / or replace the filter. Repeat the flow test. If the CleanSpace respirator continues to FAIL the Flow Test, with a new filter fitted and battery, do not use until it has been evaluated. Contact CleanSpace Technology.</i></p>

6. Remove the yellow Flow Test Cap and store for later use.

STEP 4 - DON THE CLEANSPACE RESPIRATOR WITH FULL FACE MASK

NOTE: Please this step in its entirety prior to donning the CleanSpace Respirator.

Collect the Power Unit and mask. **Ensure the mask is the correct size.**

(A neck support is optional with the Full Face Mask and does not affect operation or function of the CleanSpace Respirator)

Familiarise yourself with the Adjust Buttons and the Mask Release Buttons.

Extend both bellows to their longest setting.

Mask Release Button and Adjust Button

Press the Adjust Button on the Power Unit and pull on the bellows to extend them

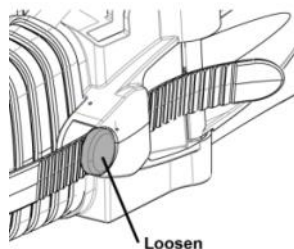
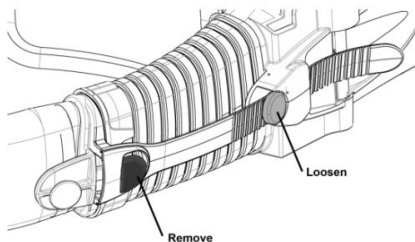



It is recommended that long hair be tied back to ensure it does not interfere with the seal between mask and face.

Don the Full Face Mask

CleanSpace Respirators

USER INSTRUCTIONS

<p>Loosen all five straps on the mask harness to their fullest extent.</p> <p>Hold the Full Face Mask in one hand. Use the other hand to pull the harness up so that the mask seal is unobstructed.</p>	
<p>Place chin in the cup at the bottom of the mask face seal.</p> <p>While placing mask on face, pull the harness over the head.</p>	
<p>Settle face into the mask face seal. Gently tighten each harness straps in turn, starting from the bottom.</p> <p>Adjust the straps until the face seal presses evenly on the face around its entire circumference.</p>	

ENSURE THAT THE MASK SEAL DOES NOT CROSS THE HAIRLINE

Check all the way around the mask seal, paying particular attention to the forehead and temples.

Ensure no loose hair between the face seal. A good fit will not be able to achieved if any strands of hair are present between face and mask.

IF YOU CANNOT ADJUST THE MASK TO AVOID THE HAIRLINE, THE MASK IS NOT SUITABLE AND MUST NOT BE WORN

<p>Perform a negative pressure seal check.</p> <p>Using the left thumb, cover the air inlet on the left hand mask AirClip.</p> <p>Inhale and hold breath. The mask should be sucked towards face. No air should enter the mask. If the mask is not sucked towards face, or if squeaking/whistling is heard, this indicates air is leaking past the seal.</p> <p>Hold breath briefly. The mask should stay sucked against face.</p> <p>A leak is present if mask seal slowly loosens, with mask moving away from your face. Readjust the mask fit and repeat the negative pressure seal check until a satisfactory seal is achieved.</p>	
--	--

IF A SATISFACTORY FIT CANNOT BE ACHIEVED, DO NOT ENTER THE CONTAMINATED AREA

Switch the Power Unit to Standby Mode by pressing the Power Button once.



Connect Power Unit to mask.

Position the Power Unit around back of neck. **Ensure filter cover hoop is facing upwards.**

Connect left mask AirClip to left Power Unit AirClip. Inhale to activate to the breath responsive Power Unit.

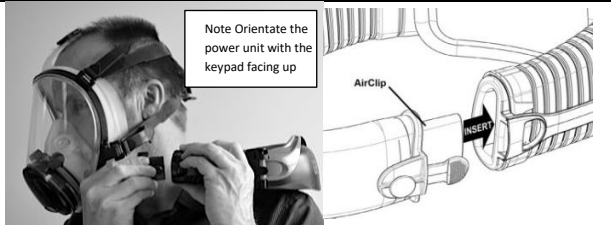

If the Power Unit does not activate, it may have been in Off Mode. Unclip the Power Unit from mask to remove.

Briefly press the Power Button to activate Standby Mode and connect again as described above.

Connect right mask AirClip to right Power Unit AirClip.



If unable to connect both AirClips to the Power Unit, ensure both bellows are extended and try again.

Connect harness to filter cover hoop.

Reach behind head and locate harness rear strap. Locate the hook at end of strap. Snap the hook onto filter cover hoop. Harness now supports the weight of the Power Unit.



Adjust Power Unit position.

Adjust the rear strap to set the height of the Power Unit.

For most users, wearing the Power Unit level is comfortable.

If your job involves looking up a lot (for instance sanding a ceiling), you may prefer to tighten the strap to raise the Power Unit.



CleanSpace Respirators

USER INSTRUCTIONS

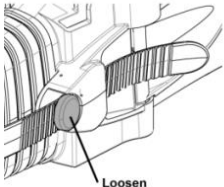
<p>Adjust the distance of the Power Unit to the back of the neck to suit the type of work to be undertaken.</p> <p>For example, if the job involves rapid movement (e.g., running up stairs) it may be preferable to set the Power Unit more snugly against the neck. If looking up a lot, it may be more comfortable to wear the Power Unit more loosely by setting further back from the neck.</p>	
<p>To move the Power Unit toward the neck, steady the mask with one hand and press on the back of the Power Unit with the other. Clicking will be heard as the adjust mechanism tightens.</p> <p>To move the Power Unit away from the neck, press and hold the Adjust Buttons on both sides and push Power Unit away from neck.</p> <p>Ensure adjustments are symmetrical.</p>	

10. Entering and Exiting the Contaminated Area

Prior to entering the contaminated area

1. Don as per section 8 or 9 depending on mask type.
2. Ensure Seal Check has been completed.
3. Ensure the Power Unit is breath responsive.
4. Ensure no alarm is sounding.
5. **Noisy Environment. Apply special precautions set out in Section 11. Working in Noisy Environments.**

In the contaminated area

1. Do not remove the CleanSpace Respirator until you have vacated the contaminated area unless you have pressing health reasons to do so (for instance you are experiencing dizziness and believe removing the respirator while leaving the contaminated area may help).
2. Leave the contaminated area immediately if any of the following conditions occur:
 - a. Any part of the system is damaged
 - b. Airflow into the mask decreases or stops
 - c. The battery or filter alarms are triggered (even if only the audible or only the visible alarm triggers)
 - d. Breathing becomes difficult
 - e. Dizziness or impaired vision
 - f. Smell or taste of contaminants
 - g. Face, eyes, nose or mouth become irritated
 - h. It is suspected that the concentration of contaminants may have reached levels at which the CleanSpace Respirator may no longer provide adequate protection.

Exiting the contaminated area

Specific exiting and decontamination procedures should be part of the workplace respiratory protection program. Follow those procedures, together with the instructions below when removing the CleanSpace Respirator.

To doff the CleanSpace Respirator, locate the knurled Mask Release Button and press to release the AirClip. **The mask release button has a rough, dimpled finish that you can feel with your fingertips. All the other buttons are smooth.**

Note: The Power Unit will automatically switch to Standby Mode approximately 10 seconds breathing is no longer detected.

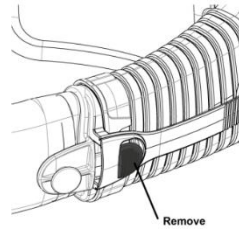

DO NOT REMOVE THE CLEANSPACE RESPIRATOR UNTIL YOU HAVE VACATED THE CONTAMINATED AREA, unless a pressing health reason exists. (e.g. Dizziness is experienced and it is believed that removing the respirator leaving the contaminated area may help)

11. Work in Noisy Environments

In most noisy environments the CleanSpace Respirator alarms are still clearly audible. However, in circumstances where alarms may not be heard, the following precautions should be taken.

- Ensure all three (3) Battery Indicator Lights are illuminated prior to entry.
- Continuous work in the area should be limited to four (4) hours. At the end of four (4) hours, leave the area and check that the Filter Warning Alarm light is not illuminated.
- If two (2) or fewer Battery Indicator Lights are illuminated, recharge the Power Unit to fully charged.
- If the Filter Warning Alarm light is illuminated, change the filter.
- If breathing difficulty is experienced, or air flow stops, leave the area immediately and doff the CleanSpace Respirator.

12. Changing the Filter

Ensure the correct filter type for the specific work environment is selected and properly fitted before using the CleanSpace Respirator. The CleanSpace Respirator is supplied with a particulate filter as standard.

IT IS ESSENTIAL THAT THE CORRECT FILTER TYPE FOR THE SPECIFIC WORK ENVIRONMENT IS FITTED.

Only change the filter outside of the contaminated area, with the CleanSpace Respirator doffed, and in Standby or Off mode. Filters need to be changed regularly. The frequency of filter change is dependent on usage patterns and the concentration of contaminants.

Dispose of used filters responsibly, treating them as non-recyclable hazardous waste (dependent on the contaminant being filtered).

FILTER WARNING ALARM

CleanSpace Respirators have a Filter Warning Alarm, which is triggered when the filter requires replacement. The Filter Warning Alarm consists of two (2) beeps, repeated once per second, and the red LED flashes.

If the Filter Warning Alarm is triggered, you must leave the contaminated area IMMEDIATELY and change the filter.

Using the CleanSpace Respirator after the Filter Warning Alarm has triggered can cause the air flow to fall below the manufacturer's Minimum Design Flow. This may result in overexposure to contaminants and lead to sickness or death.

The Filter Warning Alarm sound can be muted for fifteen (15) minutes by pressing the Power Button once. This allows time to leave the contaminated area. After fifteen (15) minutes, if the filter has not been changed, the alarm will re-trigger.

WHEN TO CHANGE A PARTICULATE FILTER

- When the Filter Warning Alarm sounds
- If the Flow Test fails
- If there is any sign of damage to the filter
- When the filter reaches its expiry date as marked on the filter label
- When the filter casing is heavily soiled
- When the filter has been exposed to water
- If there is any sign of dust or contaminants on the internal surface of the filter

Battery life is closely related to filter condition. In general, the cleaner the filter, the longer the battery life. To maximise work time between charging the battery, it is recommended to change the filter regularly.

CleanSpace filters are NOT reusable and must NOT be cleaned.

WARNING: NEVER CLEAN THE FILTER WITH COMPRESSED AIR OR A BRUSH. HEPA filters are easily damaged by the use of compressed air or by brushing.
Misuse of the CleanSpace Respirators by cleaning the filter may result in overexposure to contaminants and lead to sickness or death.

CHANGING THE PRE-FILTER (PAF-0036) FOR PARTICULATE FILTER (PAF-0035)

Figure: Changing the pre-filter (picture shows CleanSpace2 respirator but procedure is the same on all CleanSpace Respirators)

Changing the pre-filter daily is recommended. To prevent potential contamination, clean the outside of the CleanSpace Respirator prior to opening the filter cover. Cleaning can be performed with CleanSpace Cleaning wipes or a damp cloth.

To unlock the filter cover, lift the pin located at one end. The filter cover should swing open easily, exposing the pre-filter. Remove the used pre-filter and replace with a new pre-filter, taking care to keep the particulate filter in place. Swing the filter cover back into the closed position and press the pin down until it locks in place with an audible click.

CHANGING THE PARTICULATE FILTER (PAF-0035)

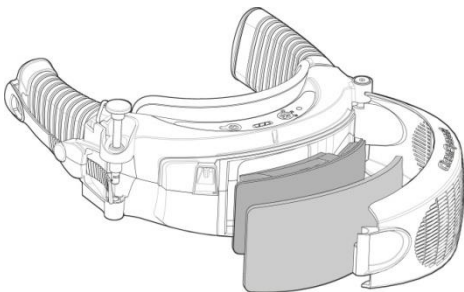
To unlock the filter cover, lift the pin located at one end. The filter cover should swing open easily exposing the filter. Remove the particulate filter and replace with a new particulate filter. Swing the filter cover back into the closed position and press the pin down until it locks in place with an audible click.

WHEN TO CHANGE A COMBINED FILTER

- When the Filter Warning Alarm sounds
- If the Flow Test fails
- If there is any sign of damage to the filter
- When the filter reaches its expiry date as marked on the filter label
- When the filter casing is heavily soiled
- When the filter has been exposed to water
- If there is any sign of dust or contaminants on the internal surface of the filter
- Gas filters must be replaced at the first sign of odour, taste, or irritation in the mask

Once any of the above conditions have been met, the filter is no longer usable, and must be discarded. CleanSpace filters cannot be cleaned.

When changing a filter, the entire filter must be discarded and replaced with a new one.

There is no way to restore the function of the activated carbon in a gas filter.

HOW TO CHANGE THE FILTERS THAT USE THE FILTER ADAPTOR (PAF-0038)

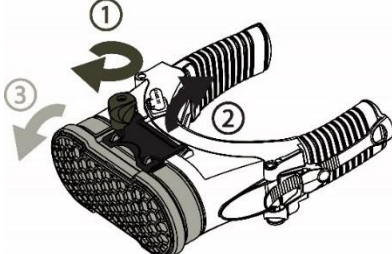
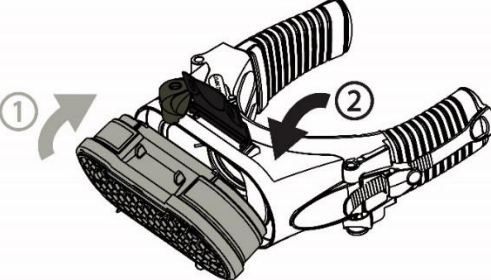
<p>STEP 1. Removing the filter from the filter adaptor</p> <ul style="list-style-type: none"> • Turn the Power Unit upside down. • Using your thumb, unlock the latch lock, and then pull the latch firmly away from the filter. • The filter can now be removed. 	
<p>STEP 2. Fitting a new filter to the filter adaptor</p> <ul style="list-style-type: none"> • Turn the Power Unit upside down. • Hold the new filter so that the blue seal is facing the adaptor. • Fit the two (2) ribs on the filter body into the slots in the top of the filter adaptor (facing down), and push into place. • Push the filter into the adaptor as shown in the figure on the right. • Push the latch down and over the two (2) ribs on the bottom of the filter body (facing up). The latch lock will move to one side automatically. When the filter is positioned correctly, two clicks are heard. • The filter is now sealed to the Power Unit and ready for use 	

13. Battery Information

Always correctly use and maintain the internal lithium-ion battery pack. Failure to do so may result in fire, explosion, or could adversely affect the performance of the CleanSpace Respirator, and result in injury, sickness, or death.

- Only use CleanSpace chargers to charge the internal battery.

- Do not charge the internal battery in enclosed cabinets without ventilation, near flammable liquids or gasses, or near sources of high heat

- Do not immerse the Power Unit in water.

- Do not use, charge, or store the device outside the recommended temperature limits. See Section 5. Limitations of Use.

CleanSpace Respirators

USER INSTRUCTIONS

The Charging Port is located on the underside of the Power Unit as shown in the figure on the right. It is protected by a flexible polymer charging port cover which should always be replaced when charging is complete.

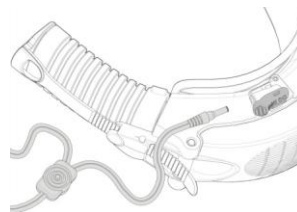

CHARGING THE INTERNAL BATTERY

**WARNING: The battery shall only be charged in non-hazardous areas.
Move out of the hazardous area before charging CleanSpace Respirators.**

- **Charging must not be performed in an explosive atmosphere.**
- To charge the internal battery, turn the Power Unit upside down, and locate the charging port. See figure above.
- Lift off the flexible polymer charging port cover. Insert the charger cable connector into the charging port. Ensure the charger is plugged into a power socket.
- Charging is complete when the Power Unit displays three (3) green solid lights. If two (2) Battery Indicator Lights are solid, and the third light is flashing rapidly, the battery is greater than 95% charged.
- When charging is complete, disconnect the charger cable from the Power Unit charging port. IMPORTANT: Ensure the charging port cover is replaced to prevent dirt and contaminants getting into the port.
- Note: The CleanSpace Respirator battery can only be charged at temperatures between 0°C and 35°C. Outside this temperature the battery will not charge.

Do not charge the battery in electromagnetically noisy environments, such as near welding machines. Doing so may damage the CleanSpace Respirator electronics.

Do not leave Power Unit plugged into its charger for more than one week at a time. Doing so may shorten the battery life.

LOW BATTERY ALARM

For information on the Low Battery Alarm, refer to Section 7. Controls and Indicators.

GENERAL BATTERY INFORMATION

CleanSpace Respirators have an internal lithium ion (Li-ion) polymer battery. Li-ion batteries have the highest energy density of all battery types and are widely used in portable electronic devices. Li-ion polymer batteries are similar to Li-ion batteries, with the difference of being packaged in a soft polymer film instead of a metal case. The soft packaging allows the cells to expand slightly under extreme heat, making them safer in fault conditions. CleanSpace Respirators use quality Li-ion polymer batteries and are designed to be viable over a minimum of 500 complete charge and discharge cycles while still maintaining at least 70% of their specified capacity.

BATTERY LIFE INFORMATION

The CleanSpace Respirator will operate with one (1) or two (2) Battery Indicator Lights illuminated. If two (2) Battery Indicator Lights are illuminated, the battery charge is between 50% and 80%, typically providing between four (4) and six (6) hours of operation. If one (1) Battery Indicator Light is illuminated, the battery charge is between 20% and 50%, typically providing between one (1) and four (4) hours of operation. When all Battery Indicator lights extinguish, the Power Unit has less than one (1) hour of operation remaining, and it is recommended that the CleanSpace Respirator be charged before use.

POWER UNIT STORAGE

To maintain the integrity of the internal battery, the Power Unit must be stored under the following conditions when not being used:

Long term storage (> 30 days)	30% - 50% RH, 18°C to 28°C
Short term storage (< 30 days)	30% - 50% RH, -10°C to 35°C

The following precautions must be followed during use of the CleanSpace Respirator

- Avoid mechanical shocks or impacts from any sharp or hard objects
- Do not use or place the CleanSpace Respirator in extreme heat, such as in direct sunlight or near heat sources. The battery will be damaged if its temperature rises above 100°C. Note: The CleanSpace Respirator will stop functioning if its internal temperature rises above 60°C or falls below -10°C.
- Do not dispose of CleanSpace Respirators in a fire.
- Do not disassemble the Power Unit case. There are no user serviceable parts inside.
- Do not use the CleanSpace Respirator if there are any signs of severe mechanical damage.

IN THE EXTREMELY RARE CIRCUMSTANCE THAT THE BATTERY IS DAMAGED AND ELECTROLYTE COMES IN CONTACT WITH EYES, FLUSH WITH WATER IMMEDIATELY AND SEEK URGENT MEDICAL ATTENTION.

14. Cleaning

It is recommended that the CleanSpace Respirator be cleaned after every use. The mask, Power Unit, neck support, and harness should be cleaned separately. Remove the mask, neck support, and harness from the Power Unit before cleaning. CleanSpace cleaning wipes are recommended as a simple and effective method of cleaning the Power Unit and mask.

CLEANING THE MASK

Before cleaning.

Half Mask: The exhalation valve cover must be removed. Locate the small slot under the lower inside edge of the valve. Use a fingernail to unclip the cover and push away from the mask. See Figure on the right.

Full Face Mask: The rain cover must be flipped up to reveal the exhalation valve leaf.

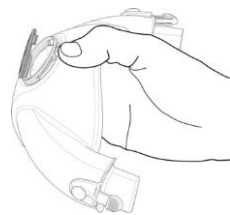

There are two methods for cleaning the mask.

1. CleanSpace Respirator Non-Alcohol Wipes for face piece

- CleanSpace Cleaning Wipes are impregnated with benzalkonium chloride, a bactericidal solution ideally suited for silicone face pieces.
- To clean the exhalation valve, remove the valve cover as per the instructions above, then gently wipe the leaf and valve seat. For Half Mask, once the mask is dry, replace the valve cover by aligning the pin opposite to the slot on the valve seat and pushing down. The valve cover will gently snap back into place.

2. Hand wash in warm soapy water

- Wash the mask thoroughly with a mild detergent in warm water at a temperature lower than 50°C.
- A soft brush or sponge can be used to remove any stubborn dirt or grit.
- To clean the exhalation valve, gently wash the warm water solution through the valve and use a sponge to gently clean the valve seat
- Rinse the mask and valve thoroughly in warm running water. **IMPORTANT:** If the mask is not rinsed thoroughly, residue from cleaning solution may irritate the wearer's skin or cause the valve to stick. For Half Mask, once the mask is dry, replace the valve cover by aligning the pin opposite to the slot on the valve seat and pushing down. The valve cover will gently snap back into place.

Drying the mask

After cleaning, allow the mask to air dry in a clean environment, with the valve facing upwards to prevent water pooling. The mask can also be hand-dried with a clean, lint-free cloth.

Note: Do not dry the mask by exposing it directly to heat (e.g. hair dryers or heaters).

CleanSpace Respirators

USER INSTRUCTIONS

IMPORTANT: The exhalation valve leaf may stick after cleaning. Before use, check that the exhalation valve leaf operates freely by gently lifting the valve.

Ensure the valve cover on the Half Mask is in place before use.

WARNING: NEVER DRY THE MASK OR EXHALATION VALVE WITH A CLOTH THAT MAY LEAVE BEHIND LINT.
Lint contamination of the exhalation valve may cause it to leak, resulting in overexposure to contaminants and lead to sickness or death.

CLEANING THE POWER UNIT

WARNING: The Power Unit contains a battery, sensitive electronics and a motor. DO NOT IMMERSE THE POWER UNIT IN WATER or use anything wetter than a damp cloth to clean it.

- After removing the mask, remove the neck support. Leave the filter in place to prevent any dust or liquids from entering the Power Unit.

WARNING: NEVER CLEAN THE FILTER WITH COMPRESSED AIR OR A BRUSH. HEPA FILTERS ARE EASILY DAMAGED BY THE USE OF COMPRESSED AIR OR BY BRUSHING.

Misuse of CleanSpace Respirator by cleaning the filter may result in overexposure to contaminants and lead to sickness or death.

- Wipe down the outside of the Power Unit using CleanSpace Cleaning Wipes or a damp cloth.
- Allow the Power Unit to air dry in a clean environment. The Power Unit can also be hand-dried with a clean lint-free cloth.
- **Note: Do not dry the Power Unit by exposing it directly to heat (e.g. hair dryers or heaters) or compressed air.**

CLEANING THE HARNESS AND NECK SUPPORT

- The harness and neck support can be washed in warm soapy water or machine washed. After cleaning, allow the harness and neck supports to air dry in a clean environment.
- **Note: Do not dry the Power Unit by exposing it directly to heat (e.g. hair dryers or heaters).**

15. Recalibration

You must recalibrate the internal pressure sensor any time that the CleanSpace Respirator is exposed to changes in temperature of more than 20°C.

Recalibration procedure:

1. With no mask attached, place the Power Unit on a flat surface with the keypad facing up.
2. With the Power Unit in standby mode (one or more Battery Indicator Light(s) illuminated), press and hold **both** the Power Button and the FLOW TEST Button.
3. When both the blue and red indicator lights illuminate, release both buttons.
4. Do not move the Power until the red and blue indicator lights extinguish; approximately(10 – 15 seconds).
5. Recalibration is complete.

The CleanSpace Respirator automatically recalibrates the system any time it is left **undisturbed in Standby Mode** for more than 20 seconds.

16. Approvals

CleanSpace Respirators are a complete respiratory protection system. In addition, some combinations of components have been approved for use in some explosive atmospheres.

Only specific combinations of components have been approved for use in explosive atmospheres.

The IECEx / ATEX / ETL approvals apply only when all components are IECEx / ATEX / ETL approved. If the equipment is to be used in an explosive atmosphere, ensure proper approval exists when purchasing spare parts and accessories.

Not all components and accessories shown in this manual carry IECEx / ATEX / ETL approval.

SEE BELOW FOR A LIST OF THOSE COMPONENTS THAT HAVE IECEx / ATEX APPROVAL

NOTIFIED BODIES**Respiratory Protection:**

BSI (2797)
John M. Keynesplein 9, 1066 EP Amsterdam,
Netherlands

IECEX

TestSafe Australia (IECEX TSA 13.0024X)
PO Box 592
Richmond NSW 2753 Australia

ETL

Intertek Testing & Certification Limited
1809 10th Street, Suite 400
Plano, TX, 75074
USA

ATEX/Explosive Atmospheres:

TUV Rheinland Industrie Services GmbH (CE0035)

ATEX

Intertek Testing & Certification Limited (ITS14ATEX27939X)
Cleeve Road, Leatherhead, Surrey, KT22 7SB
United Kingdom

ANZEx

TestSafe Australia (16.3002X)
PO Box 592
Richmond NSW 2753 Australia

RESPIRATORY PROTECTION APPROVALS (ALL CLEANSACE RESPIRATORS & ACCESSORIES)**EN 12942: 1998 + A2:2008**

TM3

AS/NZS 1716:2012

PAPR-P2 (with half face masks)
PAPR-P3 (with full face masks)

WATERPROOF APPROVAL (CLEANSACE ULTRA AND CLEANSACE EX SEE TABLE BELOW)





AS60529-2004 (IEC60529:2001)

IP RATING 66

CleanSpace Respirators

USER INSTRUCTIONS

EXPLOSIVE ATMOSPHERES APPROVALS (CLEANSPACE EX AND SEE TABLE BELOW)

<p>IEC 60079-0:2017, IEC 60079-11:2011 Ex ia I Ma, Ex ib IIB T4 Gb</p>	<p>Key to IECEx markings: Ex Explosion protected ia Type of ignition protection (intrinsic safety, very high protection) ib Type of ignition protection (intrinsic safety, high protection) I Gas Group (Methane) IIB Gas group (Ethylene) Ma Equipment protection level for underground mining (very high) T4 Temperature class (Maximum surface temperature 135°C) Gb Equipment protection class (high)</p>
<p>EN 60079-0:2018 EN 60079-11:2012  I M1 Ex ia I Ma  II 2 G Ex ib IIB T4 Gb</p>	<p>Key to ATEX markings:  Explosive area symbol I Equipment Group (underground mines) II Equipment Group (explosive atmospheres other than underground mines) 2G Equipment category (2 = High level of protection, zone 1. G = gas) Ex Explosion protected ia Type of ignition protection (intrinsic safety, very high protection) ib Type of ignition protection (intrinsic safety, high protection) IIB Explosion group Ethylene T4 Temperature class (Maximum surface temperature 135°C) Gb Equipment protection class (high)</p>
<p>Conforms to ANSI/UL Standards UL 60079-0:2019, UL 60079-11:2014</p> <p>Certified to CAN/CSA Standards CSA 60079-0:2019, CSA 60079-11:2014 Class I, Division 2, Groups C and D, T4 Class I, Zone 1, AEx ib IIB T4 Gb</p> 	<p>Key to ETL markings: Class I, Division 2 Explosive Atmosphere (gas or vapour), Area classification (A place in which an explosive atmosphere is likely to occur in normal operation) Groups C and D Gas group (Ethylene and Propane) T4 Temperature class (Maximum surface temperature 135°C/275°F) Class I, Zone 1 Explosive Atmosphere (gas or vapour), Area classification (Present intermittently) AEx Explosion Protected approved to US Standards ib Type of ignition protection (intrinsic safety, high protection) IIB Gas group Ethylene Gb Equipment protection class (high)</p>

COMPONENTS WITH IECEX AND ATEX AND ETL APPROVAL

Any combination of these components carries the explosive atmospheres approvals listed above.

Power Unit and Filter Cover

Product Code	Description
PAF-0060	CleanSpace EX Power Unit (Full kit, without mask)
PAF-0061	Power Unit – CleanSpace EX
PAF-0065	Standard Filter Cover – CleanSpace EX
PAF-0067	Standard Filter Cover – CleanSpace Ex
PAF-0078	Conductive Filter Adaptor - CleanSpace EX

Filters – For Particulates

Product Code	Description
PAF-0035	Particulate Filter P3 / TM3 P SL R
PAF-0037	Particulate Filter P3 / TM3 P SL R High Capacity
PAF-1037	Particulate Filter HEPA / HE High Capacity
PAF-1003	Particulate Filter HEPA / HE High Capacity

Combined Filters – For Gases & Particulates

Product Code	Description
PAF-0091	Combined Filter ABE1P3 (Australia)
PAF-0076	Combined Filter ABEK1P3 (Australia)
PAF-0050	Combined Filter TM3 A1 P SL R (Europe)
PAF-0051	Combined Filter TM3 ABE1 P SL R (Europe)
PAF-0052	Combined Filter TM3 ABEK1 P SL R (Europe)
PAF-0077	Combined Filter TM3 A2 P SL R (Europe)

Masks

Product Code	Description
PAF-0064	Mask: Half Small - EX
PAF-0062	Mask: Half Medium - EX
PAF-0063	Mask: Half Large - EX

Accessories & Spares: Harness, Neck Supports & Battery Charger

Product Code	Description
PAF-0073	Harness (for half masks)
PAF-1028	Neck support – Small
PAF-1012	Neck support – Medium
PAF-1013	Neck support – Large
PAF-1101	Battery Charger EX

ACCESSORIES FOR WHICH IECEX / ATEX / ETL CERTIFICATION IS NOT REQUIRED

The accessories listed below are used outside the hazardous area and can be used with CleanSpace EX without impacting its explosive atmospheres certifications.

Accessories

Product Code	Description
PAF-1005	Flow Test Cap (for checking filter condition and battery charge)
PAF-0025	Adaptor for Fit Testing (for half masks)
PAF-1009	Seal Check Cap (for positive pressure seal tests on Half masks)

COMPONENTS THAT DO NOT HAVE IECEX / ATEX / ETL APPROVAL

These components can be added to the system without affecting the respiratory protection approvals listed above. They have **not** been certified for use in explosive atmospheres.

Power Units

Product Code	Description
PAF-0034	CleanSpace2 Power Unit (Full Kit, without mask)
PAF-0070	CleanSpace Ultra Power Unit (Full Kit, without mask)

Masks

Product Code	Description
PAF-0033	Mask: Half Small
PAF-1010	Mask: Half Medium
PAF-0027	Mask: Half Large
PAF-1014	Mask: Full Face Mask Medium / Large
PAF-1106	Mask: Full Face Mask Small

Combined Filters – For Gases & Particulates

Product Code	Description
PAF-0038	Filter Adaptor - all large-case filters (PAF-0037, -0050, -0051, -0052, -0077, -0076, -0091)

Pre-Filters and Coveralls

Product Code	Description
PAF-0036	Particulate Pre-Filter (Standard)
PAF-0057	Particulate Pre-Filter (Large Case Filters)
PAF-0058	Particulate Pre-Filter and Coverall (Standard)

17. Specifications

Air Flow	Manufacturers minimum design flow: 120 litre/minute <i>Breath-responsive, with max inflow to mask 120 – 200 litre per minute, dependant on altitude, filter, and battery condition.</i>
Operating Temperature Range	-10°C to 45°C. (Note: Explosive Atmospheres approvals apply up to maximum ambient temperature of 40°C) The motor will shut down if the temperature of the battery pack rises above 60°C or falls below -10°C
Operating Humidity Range	Zero to 90%, non-condensing
Operating Altitude Range	Approximately sea level to 1200m
Charging Temperature Range	0°C to 35°C <i>Below 0°C and above 35°C the battery may not accept charge</i>
Storage Conditions	Short term storage under 30 days: Out of direct sunlight, in a clean, dry environment (30% - 50% RH), -10°C to 35°C. <i>To maintain the integrity of the internal battery, the respirator must be stored under the following conditions when it will not be used for longer than one (1) month</i> Long term storage (> 30 days): Out of direct sunlight, in a clean, dry environment (30% - 50% RH), 18°C to 28°C.
Shelf Life (when stored as specified)	<i>Charging the battery every 6 months is recommended if the CleanSpace Respirator is not in use.</i> Particulate Filters: 3 years Gas and Combined Filters: 3 years
Battery Type	Lithium Ion Polymer
Run Time	Up to 8 hours. Certified to a minimum 4 hours. <i>Run time is strongly influenced by work rate, filter condition, atmospheric pressure, and other factors. The run time specified above assumes moderate work rates at sea level with a clean filter. Different conditions will produce widely varying run times.</i>
Recharge Time	2 hours (to 95%)
Low Battery Voltage Alarm	Triggers when the remaining run time is around 5 to 10 minutes. <i>Audible alarm, 3 beeps, repeated every second, 75dB(A) at ear.</i>
Filter Warning Alarm	Triggers when the filter requires replacement. <i>Audible alarm sounds until a key is pressed, two (2) beeps repeated every second, 75dB(A) at ear, and red filter LED flashes. When the alarm first sounds, and if the battery is almost completely run flat, the maximum flow that can be delivered has been reduced to about 140 litre/minute.</i>
Charger	Input: 100 – 240VAC, 50 – 60 Hz. Output: 14.7 VDC, 24 Watts
Intrinsic Safety	CleanSpace EX is certified to IECEx and ATEX and ETL standards. See Approvals above.

18. Product Warranty

This product has been manufactured using quality parts and processes.

CleanSpace Technology Pty Ltd warrants that the product is free from defective workmanship and parts for a period of two (2) years from the date of original purchase provided the product has been used, cleaned and maintained in accordance with these instructions and CleanSpace Technology's recommendations. This warranty does not include consumable parts, such as filters and face masks, which must be replaced regularly by the user. Consumable parts are warranted up to the point of use, provided they have been stored correctly and are within their expiry date. This warranty does not cover:

- Where the product has been used for industrial purposes outside the recommendations of CleanSpace Technology Pty Ltd;
- Where damage has been caused by misuse, neglect, accident, or excessive wear and tear.

Any claim under this warranty must be made within two (2) year of the date of purchase of the product. All warranty claims must be made by returning the defective product to your supplier together with the proof of purchase. The purchaser is responsible for all freight. In the event that any part of the product is found by CleanSpace Technology to be defective, CleanSpace Technology will either repair or at its discretion replace the faulty part.

This warranty is provided in addition to other rights and remedies you have under law. You are entitled to replacement or refund for a major failure. You are also entitled to have the goods repaired or replaced if the goods fail to be of acceptable quality and the failure does not amount to a major failure.

This warranty is given by:

CleanSpace Technology Pty Ltd ABN 24 146 453 554
Unit 5, 39 Herbert St, St Leonards NSW 2065 Australia;
T. +612 8236 4000 E. sales@CleanSpaceTechnology.com

Disclaimer:

Whilst CleanSpace Technology has made every effort to ensure that the details and information given in both our printed and online publications are accurate at the time of issue, full technical specifications are not necessarily included. Furthermore, CleanSpace Technology has a policy of continuous improvement and the right is reserved to alter details and information as the need arises. Accordingly, the Customer should check any details and information they wish to rely on with CleanSpace Technology at the time of purchase. CleanSpace Technology cannot accept liability in respect of any errors or omissions herein contained or for any loss or damage malfunction or consequential loss arising from reliance upon our publication. The Customer will be responsible for any risk to health or safety from goods in the Customer's possession and/or control. The Customer's attention is drawn to the fact that statutory regulations and recognised codes of practice exist covering the use and handling of some goods (including safety products). The Customer must ensure that persons who use the goods receive adequate training and safety literature. No page or part of this manual may be reproduced in any form without written permission of the copyright owner shown above. CleanSpace Technology reserves the right to correct typographical errors. All information is correct at the time of going to print.